

# Lion

Tunable External Cavity  
CW Quantum Cascade Laser  
Littman/Metcalf Configuration

Scientific Lasers

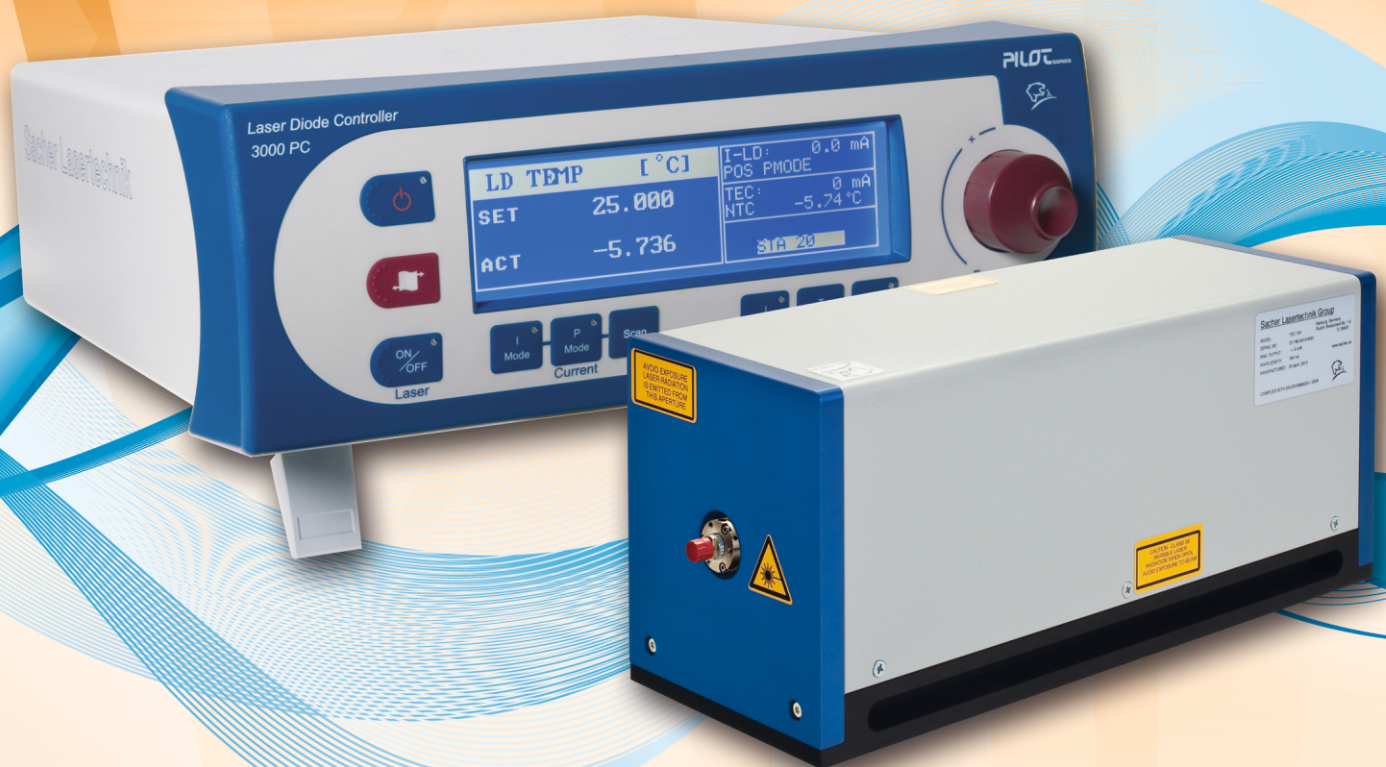



# How does our Laser tune modehop-free ?

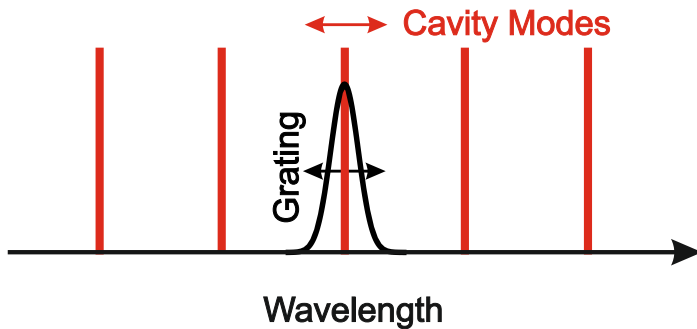

**Lion**

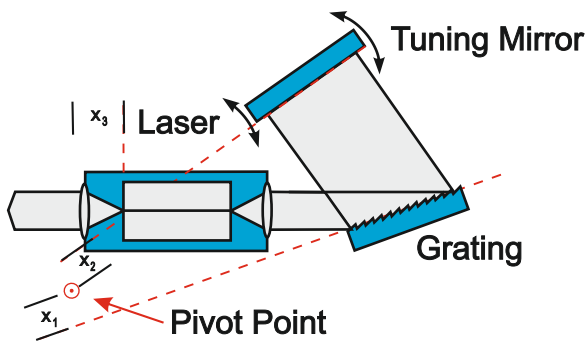
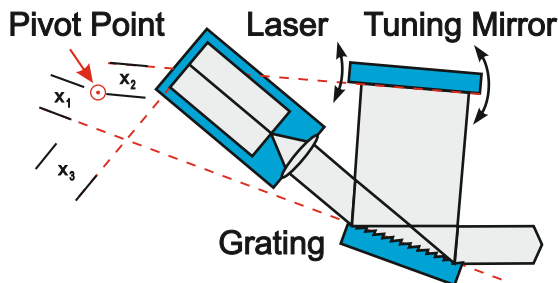

## Physical Basics

The emission wavelength of a laser is defined by two features. The first condition is the cavity mode. The second condition is the amplification range of the gain medium. Since diode lasers have an extremely wide gain region, it is necessary to put a wavelength selective medium inside of the cavity like a grating. In order to tune such a laser modehop-free, it is required to synchronize the grating defined wavelength with the cavity defined wavelength [1].

## Technical Solution

Sacher Lasertechnik has realized the synchronization between grating defined and cavity defined wavelength by only a simple rotation of the mirror. The adjustment of the pivot point is done during the wavelength scanning operation of our Littman/Metcalf laser system according to our patent no. 5,867,512. Due to this special method, we are able to ensure the best modehop free tuning behavior. An increase of the output power and the total performance of the Littman/Metcalf laser is achieved by using a high efficiency grating and outcoupling the light of the rear facet of the laser diode. With this approach, we are able to increase the output power to more than 100mW.

## Dimensions

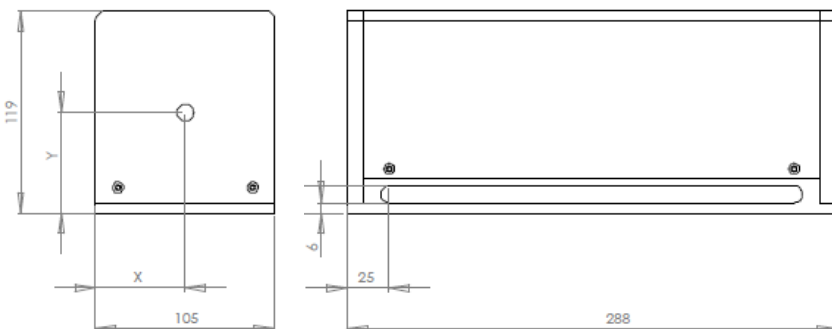

## Technical Realization

The drawings on the left hand side show the technical realization and the dimensions of the XQ500 external cavity diode laser system. Due to using an alignment insensitive cavity design and a flexmount concept our Littman/Metcalf laser diode systems are excellent turn-key devices.

[1] M. G. Littman, H. J. Metcalf, Appl. Opt. 17, 2224, 1978

# Key Features of our Littman/Metcalf Laser System

## Available CW-QCL Modules

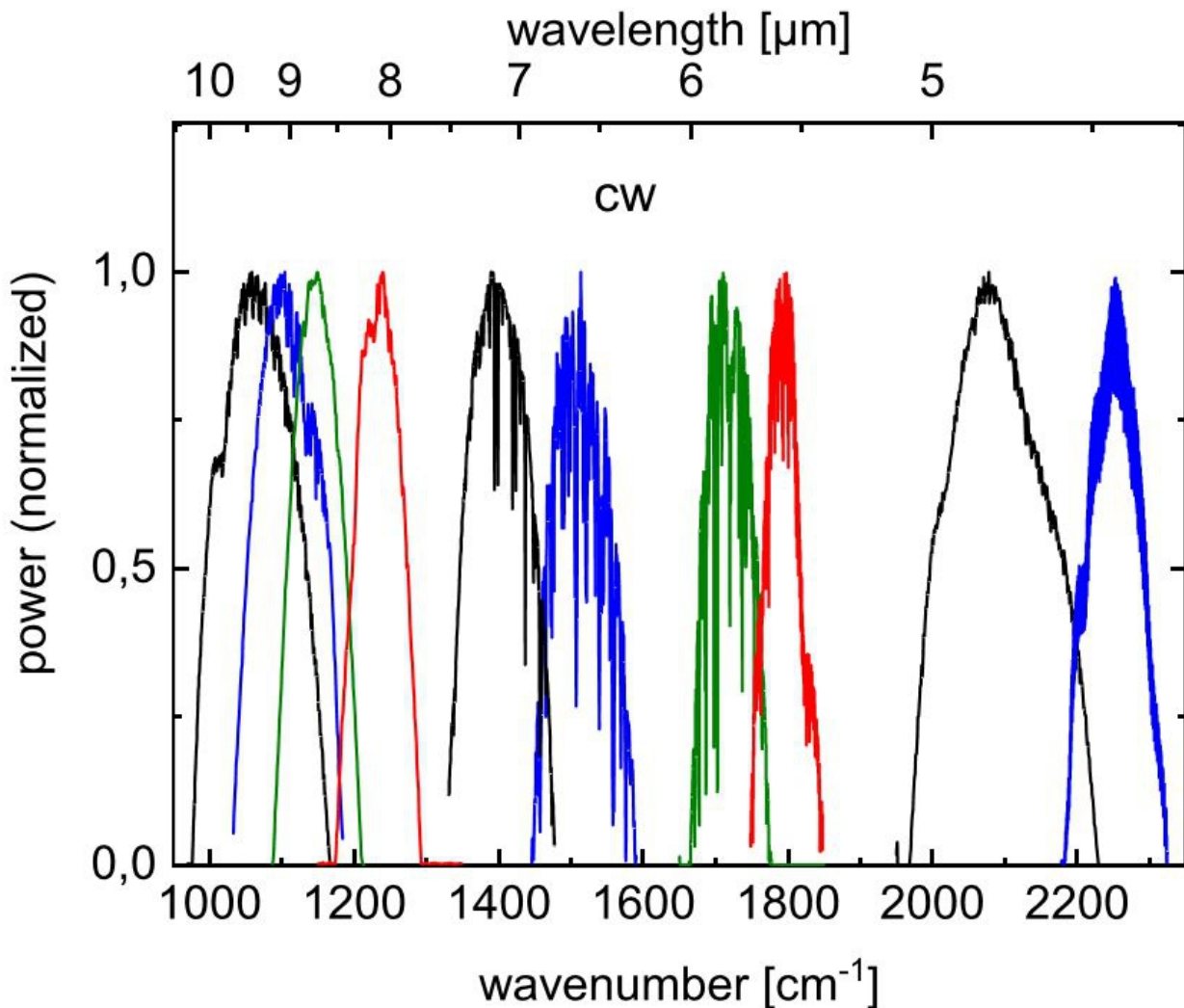

## High passive stability

Realizing the pivot axis of the tuning grating and the cavity adjustment via flex-mounts ensures the highest passive stability of our Littrow laser system. As a result, we achieve a robust and highly stable external cavity diode laser system with excellent values for the long term laser linewidth.

## Specification: Summary

Output Power	50 ... 200 mW (depending on wavelength)
Wavelength	4200 nm ... 10000 nm with multiple laser heads
Wavelength Tuning	300 nm ... 1000 nm (depends on wavelength)
Piezo Tuning	3 GHz ... 10 GHz (depending on wavelength)
Piezo Tuning (wide piezo option)	12 GHz ... 40 GHz (depending on wavelength)
Beam Quality $M^2$	< 1.5
Further Specification	Please contact us for further specification

# Application Example

## Wavelength Tuning

### Smooth Mode-Hop Free Tuning

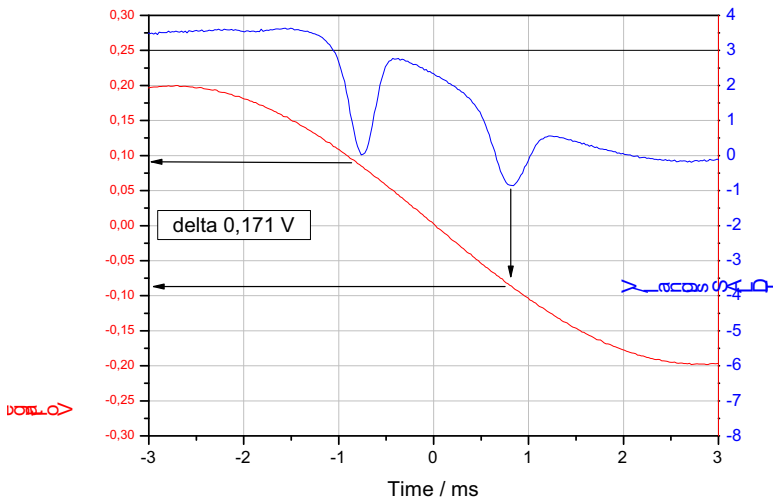

### Total Tuning Range

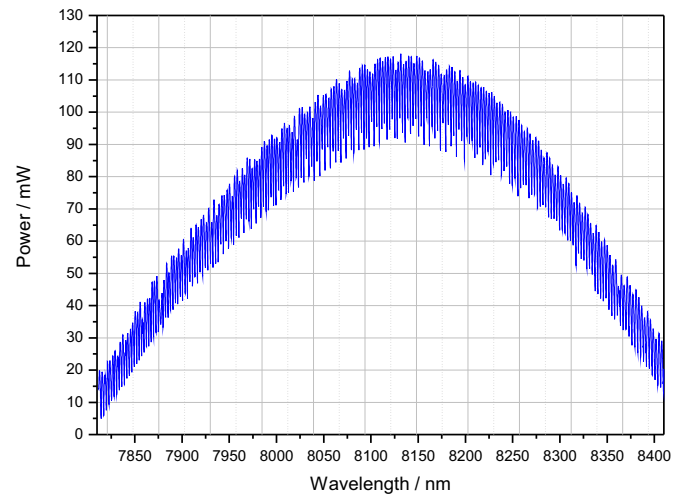

High resolution spectroscopy requires laser features like narrow linewidth, high passive stability, exact adjustable wavelength as well as an excellent modehop free fine tuning ability. The figure summarizes experimental data which have been determined with our Littman/Metcalf laser system. The lines shows an absorption signal of the Rotational Absorption Band of N<sub>2</sub>O in the 8000nm wavelength regime.

## About Sacher Lasertechnik

### Company Profile

Sacher Lasertechnik is leading manufacturer of tunable external cavity diode lasers (ECDLs) with more than 25 years of experience. The product range includes anti-reflection coated diode lasers, ECDLs in Littrow and in Littman/Metcalf configuration as well as driver electronics for the LD and sophisticated measuring electronics. Please contact us with your measurement requirements. We would be proud to support you with our competence.

### Please contact us

Sacher Lasertechnik  
GmbH  
Hedwig-Jahnow-Str. 12  
D-35037 Marburg/Lahn  
Germany  
Tel.: +49 6421 305 - 0  
Fax: +49 6421 305299

Sacher Lasertechnik  
LLC  
5765 Equador Way  
Buena Park, CA90620  
U. S. A.  
Tel.: 1-800-352-3639  
Fax: 1-714-670-7662

Email: [contact@sacher-laser.com](mailto:contact@sacher-laser.com)  
Web: <http://www.sacher-laser.com>

